



DAS HERZ DER FRISCHE

SEMI-HERMETIC RECIPROCATING COMPRESSORS

50 Hz // KP-130-11 EN

TRANSCRITICAL APPLICATIONS



WITH IQ MODULE

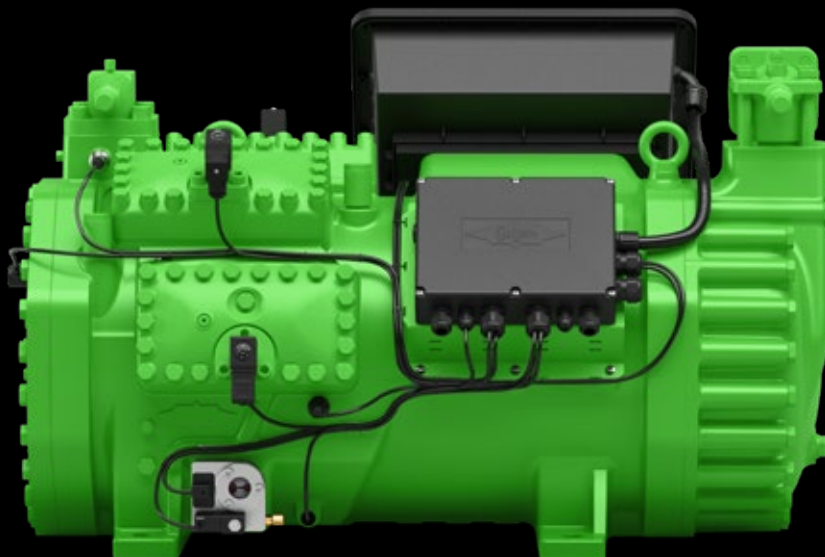

ECOLINE // ECOLINE+



CO₂



INTELLIGENT
PRODUCTS



ADVANCED MOTOR
TECHNOLOGY

BITZER Innovation Targets

Products for refrigerants with low greenhouse warming potential (GWP)

- // for naturally appearing substances
- // for new refrigerants like R1234yf, R1234ze(E) and low-GWP-blends

These refrigerants reduce the direct contribution of refrigeration systems to global warming.

Products with high efficiency in full and part load

- // Efficiency improvements of motor and mechanics
- // high system efficiency in part load operation
 - by optimised mechanical capacity regulation
 - by specially developed frequency inverters

This reduces the indirect contribution to global warming by saving energy.

Simple handling and serviceability with advanced electronic modules

- // Electronic components for
 - Data logging
 - Capacity regulation
 - Actuation of accessories
- // Unified user software for simple configuration. Choose compressor or condensing unit and refrigerant. Ready.

This makes it simple to fully utilize the efficiency potential of our products and optimise operation.

Semi-hermetic reciprocating compressors for CO₂

Content	Page
ECOLINE series for transcritical CO₂ applications	3
ECOLINE+ series for transcritical CO₂ applications	4
Accessories	5
Application limits	8
Performance data	9
Technical data and performance data	11
Dimensional drawings	13

Introduction

The refrigerant R744/CO₂ is used in many commercial and industrial refrigeration systems, as well as in heat pumps.

The ECOLINE compressors for transcritical applications are developed for medium temperature applications, heat pumps, heat recovery, and as parallel compressors in booster systems, and are also suitable for similar applications.



ECOLINE series for transcritical CO₂ applications

BITZER compressors for transcritical CO₂ applications have been used worldwide since 2004 with great success. The 2-, 4-, 6- and 8-cylinder compressors allow a wide range of applications, providing highest energy efficiency and operational reliability. By using new ECOLINE housings with flow optimized suction and discharge gas channels and high efficient motors, BITZER can offer an optimum efficiency for all CO₂ applications and markets.

Highlights and technical features

- // The capacity range covers displacements from 3.3 m³/h to 38.2 m³/h
- // Housing with high pressure strength and no bottom plate. Maximum permissible pressure levels:
 - High pressure side 160 bar
 - Low pressure side 100 bar
- // Wear-resistant drive gear with further developed multilayer bearings

- // Optimized oil management
- // Quiet and low vibration
- // Particularly well suited to the operation with frequency inverter in order to increase and control capacity
 - Standard speed range:
 - 2MTE ..2KTE: 30-75 Hz
 - 4PTE ..4DTE: 25-70 Hz
 - 4CTE: 25-65 Hz
 - 6FTE ..6CTE: 25-70 Hz
 - 8FTE ..8CTE: 30-60 Hz

- // High energy efficiency
 - suction gas-cooled motor – very suitable for speed regulation
 - very efficient working valves, special drive gear geometry
 - cylinder heads with separate, thermally isolated high and low pressure chambers
- // Wide application range
 - in commercial and industrial refrigeration, air condition and heat pump systems

Capacity range ECOLINE series

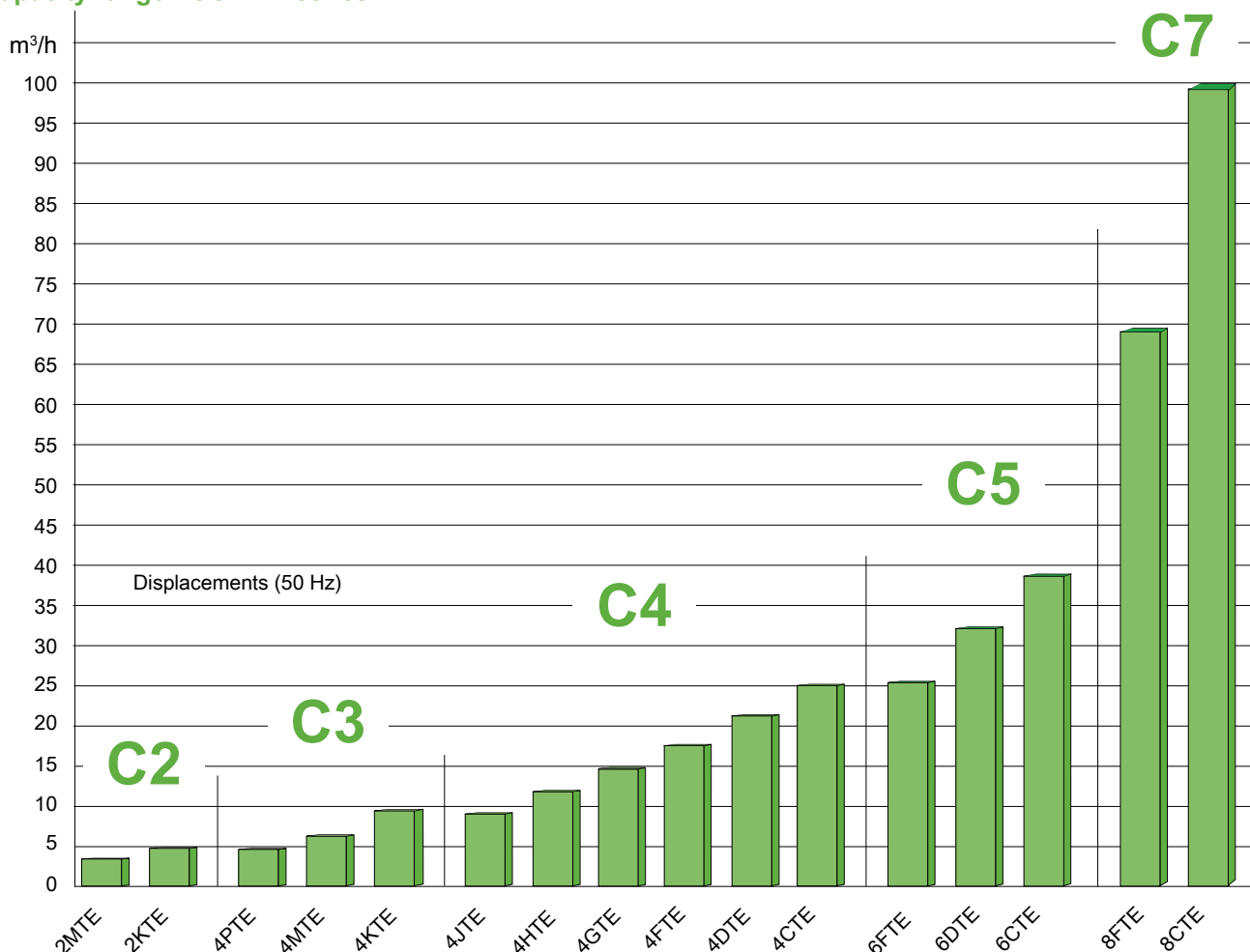

ECOLINE + series for transcritical CO₂ applications

BITZER ECOLINE + provides the highest possible eco-efficiency. The natural refrigerant CO₂ is combined with highest efficiency. Smart electronics with easy application are added. The Line Start Permanent Magnet Motor (LSPM) improves the motor efficiency and increases the seasonal performance. A high seasonal performance reduces the TEWI (Total Equivalent Warming Impact) and operating costs and thus minimizes the refrigeration and A/C industry's contribution to global warming.

Annual Energy Consumption [kWh]

- AS: asynchronous motor
- LSPM: LSPM motor
- SEPR (Seasonal Energy Performance Ratio)

Line Start Permanent Magnet Motor (LSPM)

- // High efficiency of a synchronous motor due to permanent magnets
- // Asynchronous (AS) motor start due to squirrel cage rotor
- // Rotor of a LSPM motor synchronizes with the operating frequency, rotor losses become zero
- // Increased efficiency over wide working range of the motor, see fig. 1
- // Annual efficiency increasing in the range up to 14% due to highest improvements in the most common operating area, see fig. 2

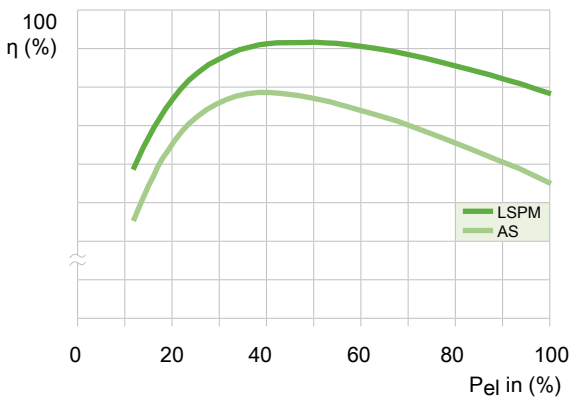
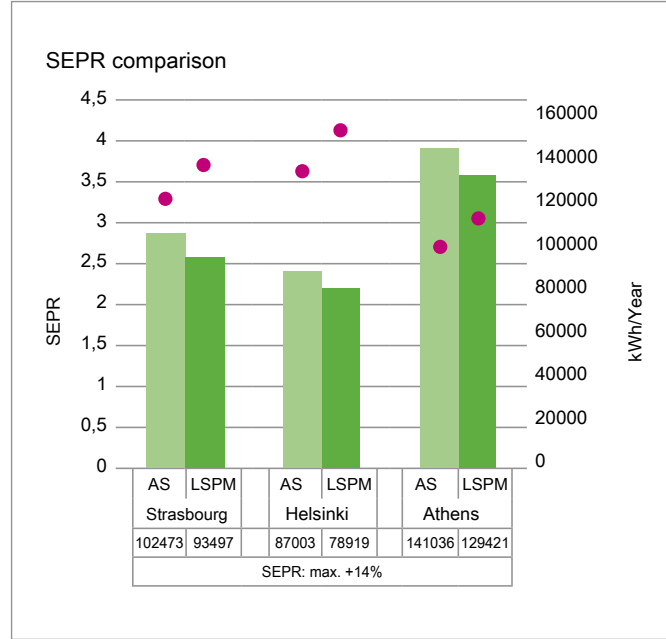

Fig. 1: Comparison LSPM and AS motor: motor efficiencies versus relative power input



- // The technology combines the higher efficiency of the synchronous motor with the robustness and easy use of the asynchronous motor
- // LSPM motors can either be connected directly to the power supply system or be operated with frequency inverter (frequency range defined by BITZER)
- // A fast overcurrent protection device is required in order to avoid a demagnetization.

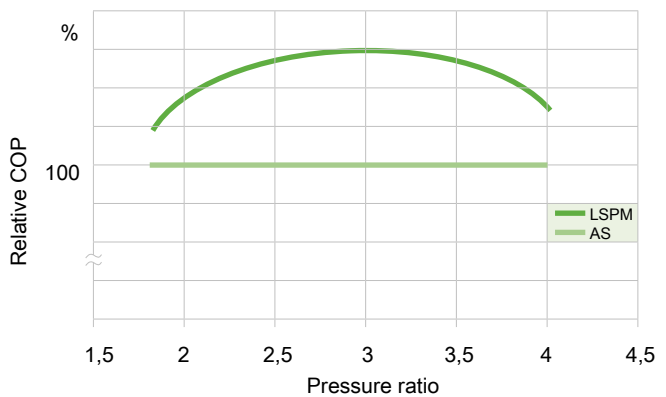
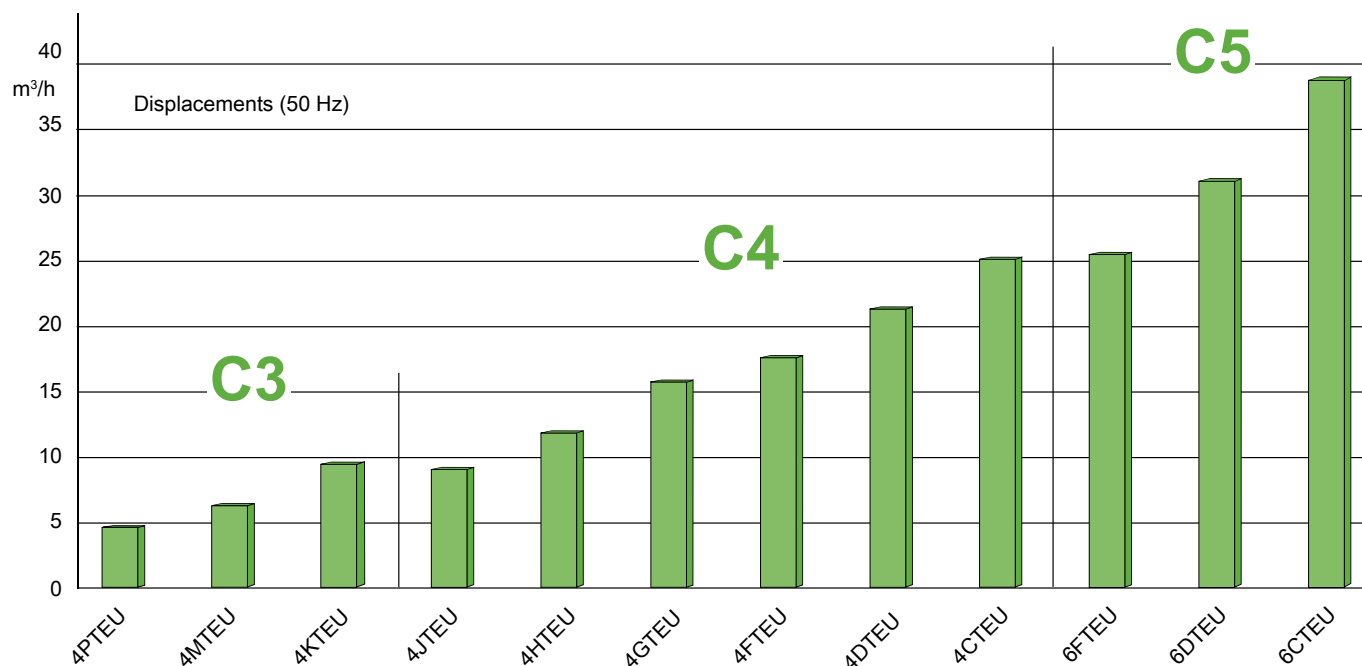

Fig. 2: COP improvement LSPM compared to AS motor at constant suction conditions

Capacity range ECOLINE+ series



Accessories

The ECOLINE compressors for transcritical CO₂ applications offer a comprehensive and proven set of options.

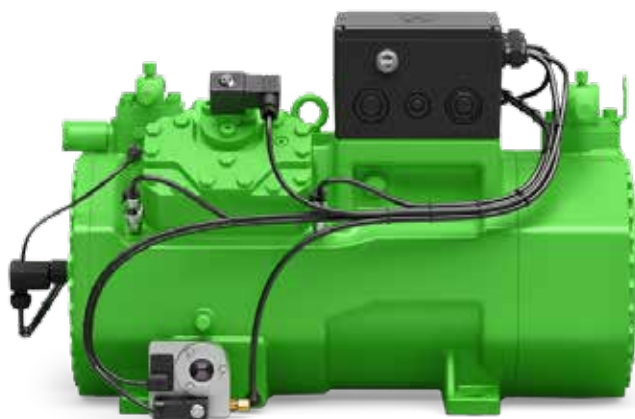

Fully equipped 4 cylinder compressor with discharge gas temperature sensor, pressure transmitters, oil heater, VARISTEP and OLM-Q1.

See price list for scope of delivery

IQ MODULE CM-RC-01

The new generation of extended BITZER compressor modules reliably operates, monitors and protects reciprocating compressors and communicates with the superior system controller. Sensors and actuators are prewired and preconfigured in the BITZER factory. Option: 4PTEU .. 6CTEU

The new, extended protection concept

Intelligent actuation of the following components to improve the system efficiency:

- // Oil heater
- // VARISTEP capacity control
- // oil level monitoring with OLM-IQ

Monitored compressor parameters:

- // Motor and discharge gas temperature
- // High-pressure switch
- // Oil pressure (with the new oil pressure switch) or oil level

Diagnosis:

- // An early warning system signals critical operating conditions
- // Data log of all digital and analog inputs and outputs
- // Alarm and warning history
- // Runtime and load statistics

Communication:

- // via Modbus (standardized interface)
- // via Bluetooth
- // Configuration and operation monitoring via the BEST SOFTWARE
- // Status LED for quick diagnosis

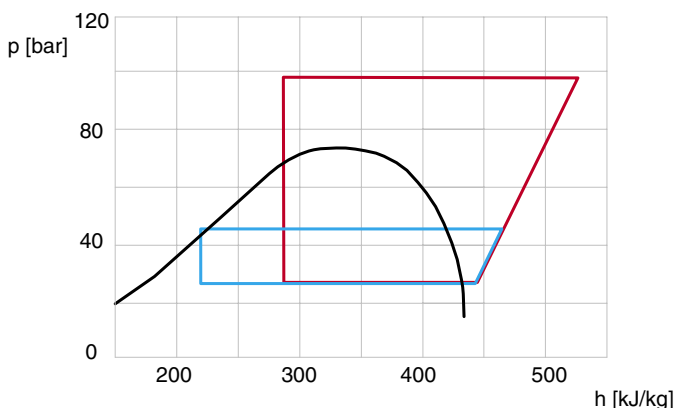

Fig. 3: Example of summer (—) and winter (—) operation in p,h-diagram



Capacity control VARISTEP

New mechanical capacity control especially for CO₂ compressors. Optionally available only with IQ MODULE.

- // Designed for high pressures and pressure differences in transcritical CO₂ applications
- // Adaption of the capacity to the demand in a wide range from 100% to ca. 10% to
 - cover the large differences between summer and winter operation
 - reach exactly matching capacity in compound operation
- // Innovative control piston design for higher cycling frequency
- // Virtually stepless capacity control, with easy and effective modulation by the CM-RC-01 module
- // Rapid reactions to system changes, and thus, minimizations of pressure fluctuations
- // Increased overall system efficiency through more stable and higher average suction gas pressure

VARIPACK – External BITZER frequency inverters

For easy and safe capacity control, BITZER VARIPACK series offers a new generation of intelligent frequency inverters that can be used with all BITZER reciprocating compressors.

The new VARIPACK frequency inverter series was specially developed for refrigeration and operation of BITZER refrigeration compressors. The focus of the development was the easy use, the reliability and the high performance of the frequency inverters.

Selection and assignment

The VARIPACK frequency inverters are completely integrated in the BITZER SOFTWARE and can be found under the button "Accessories".



F.Y
IP66



F.U
IP20



F.W
IP55

 FREQUENCY
INVERTER



Via PC, a lot of BITZER IQ products may be configured with the BEST SOFTWARE. With its intuitive user interface displays a complete operating status overview including data log for easy maintenance and service. This is completely in line with our innovation targets.

Easy Configuration

- // Easy device parameterization
- // Storage and installation of device and compressor setups
- // Safe and easy firmware update

Reliable online diagnosis

- // Display of all connected sensors, e. g. pressure transmitters, temperature sensors, oil level switches, digital and analog inputs and outputs
- // Current operating point in the application limit
- // Current capacity control status

Comfortable analysis

- // Data log download and visualization of all operating parameters
- // Alarm list with integrated help function for easy maintenance and service

Communication

- // Via BEST interface converter and Bluetooth



See price list for scope of delivery

Application limits

based on 10 K suction gas superheat

2MTE(U)-5(L)K, 2KTE(U)-7(L)K, 4PTE(U)-7(L)K,
4MTE(U)-10(L)K, 4JTE(U)-15(L)K, 4HTE(U)-20(L)K,
4GTE(U)-30(L)K, 4FTE(U)-30(L)K, 6FTE(U)-50(L)K

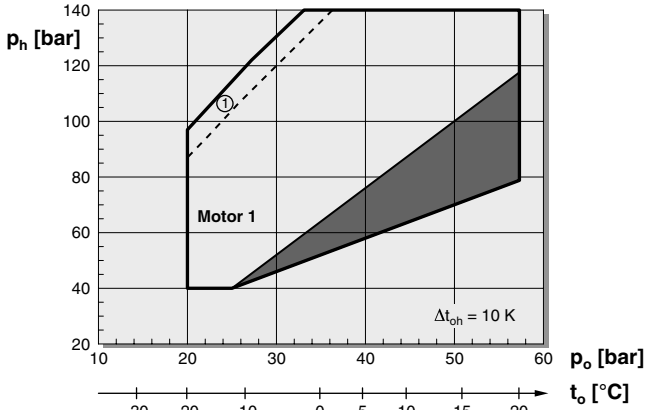

6DTE(U)-50(L)K, 4KTE-12K

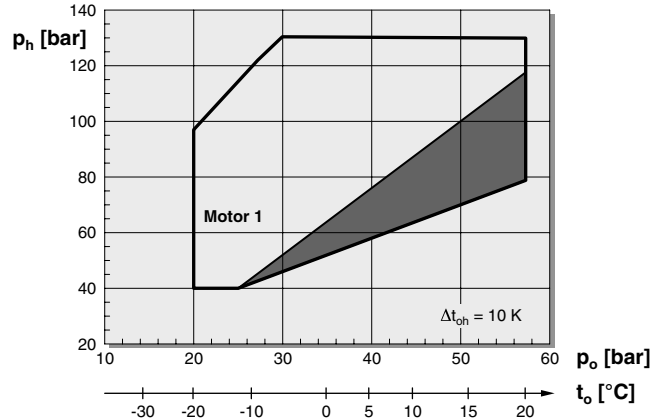

2MTE(U)-4(L)K, 2KTE(U)-5(L)K, 4PTE(U)-6(L)K,
4MTE(U)-7(L)K, 4KTE(U)-10(L)K, 4JTE(U)-10(L)K,
4HTE(U)-15(L)K, 4GTE(U)-20(L)K, 4FTE(U)-20(L)K,
4DTE(U)-25(L)K, 4CTE(U)-30(L)K, 6FTE(U)-35(L)K,
6DTE(U)-40(L)K, 6CTE(U)-50(L)K

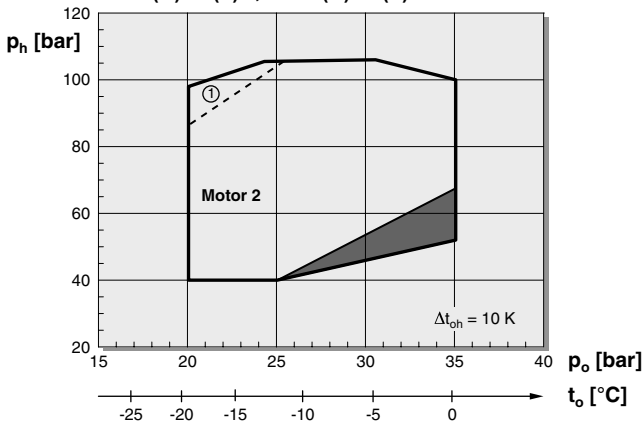

8FTE-140K

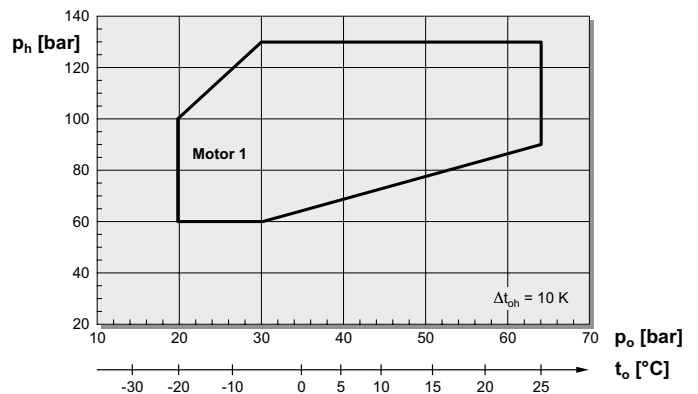

8FTE-100K, 8CTE-140K

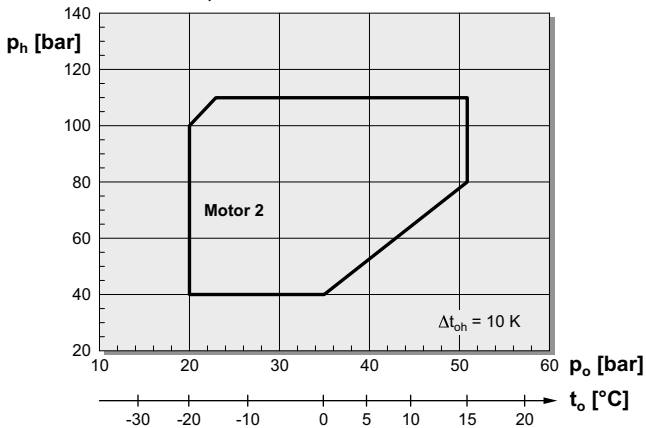

- t_o Evaporating temperature (°C)
- Δt_{oh} Suction superheat (K)
- p_o Suction pressure abs. (bar)
- p_h High pressure abs. (bar)
- ① Range with limitations for the compressors 4PTE(U)

- Mind operating parameters
 - minimize suction pressure variations
 - consider maximum cycling frequency
 Consultation with BITZER is recommended.

Suction gas superheat > 10 K causes a reduced application range – requires, if necessary, controlled refrigerant injection into the suction line and thermal protection by means of a discharge gas temperature sensor.

Oil charge

- BSE85K: Standard
- BSG68K: Option as standard oil charge and recommended with suction pressure >40 bar and/or high pressure >120 bar (e. g. heat pumps)

Performance data



The BITZER SOFTWARE is available in many languages as download for Windows or online version. It is compatible with all browsers and always up to date. The program is ideal for tablets and smartphones.

The BITZER SOFTWARE covers:

- // Performance data for all common refrigerants at freely selectable operating conditions
- // All relevant technical data
- // Calculation results and individually designed performance tables for compressors
- // Seasonal calculation
- // Parallel compounds
- // Available accessories and their selection
- // All relevant technical documents
- // More BITZER products

www.bitzer-software.com

The screenshot displays the BITZER Software interface for selecting and viewing technical data for a compressor. The interface includes a navigation menu at the top right with options: Start page, Calculation, Options, Extra, and Homepage. The main window is titled "BITZER Software v6.17.0 rev2725" and features a "Show Overview" checkbox.

Compressor Selection Parameters:

- Mode: Refrigeration and Air con.
- Refrigerant: R744 (CO₂)
- Reference temperature: Over point temp.
- Compressor type: Transcritical
- Series: Standard
- Operating mode: Transcritical
- Motor version: all
- Compressor selection:
 - Cooling capacity: 16 kW
 - Compressor model: 6CTE-50K
 - Incl. former types
- Operating point:
 - Evaporating SST: -5 °C
 - discharge pressure: Auto
- Operating conditions:
 - Gas cooling subst.: 25 °C
 - Suct. gas superheat: 10 K
 - Useful superheat: 100 %
- Capacity control:
 - without
 - External FI: 80 Hz
 - Stopped: 100%
- Power supply:
 - Power frequency: 50Hz
 - Power voltage: 400V-PW (40P)

Technical Data Summary:

Tentative Data
 *Compressor-Performance data certified by ASERCOM (see T.Data/ Notes)
 *according to EN12900 (10K suction gas superheat)

Compressor	6CTE-50K-40P
Capacity steps	100%
Cooling capacity	124.5 kW
Cooling capacity *	124.5 kW
Evaporator capacity	124.5 kW
Power input	40.0 kW
Current (400V)	78.3 A
Voltage range	300-400V
Gas cooler capacity	164.5 kW
COPEER	3.11
Mixes flow	2451 l/h
Discharge gas temp. w/o cooling	87.6 °C
optimal high pressure	75.0 bar(a)

The interface also includes a schematic diagram of the compressor system with various temperature points: 25.0°C, 87.6°C, 5.0°C, and -5.0°C. A "CERTIFIED PRODUCT ASERCOM" logo is visible at the bottom right of the data section.



ASERCOM certified performance data

The Association of European Refrigeration Component Manufacturers (ASERCOM) has implemented a procedure of certifying compressor performance data.

The high standard of this certification is assured by

- // plausibility checks of the data performed by experts
- // regular random tests at independent institutes

These high efforts result in the fact that only a limited number of compressors can be submitted. Due to this not all BITZER compressors are certified yet.

Performance data of compressors which meet the strict requirements may carry the label "ASERCOM certified product".

All certified compressors and further information are listed on the ASERCOM website (www.ASERCOM.org).



In the BITZER SOFTWARE the appropriate compressors are marked with this label.

Explanation of model designation

Example

4 M T E U – 10 L .F4 K

Index for number of cylinders

4 **M** T E U – 10 L .F4 K

Identification letter for bore x stroke

4 M **T** E U – 10 L .F4 K

Identification letter for transcritical CO₂ application

4 M T **E** U – 10 L .F4 K

Identification letter BITZER ECOLINE

4 M T E **U** – 10 L .F4 K

Identification letter BITZER ECOLINE+

4 M T E U – **10** L .F4 K

Code for motor size

4 M T E U – 10 **L** .F4 K

Motor codes: LSPM motor

4 M T E U – 10 L **.F4** K

Code for frequency inverter

4 M T E U – 10 L .F4 **K**

Identification letter for oil charge

K = BSE85K, Z = BSG68K

Technical data and performance data

Performance data 50 Hz

based on 10 K suction superheat and compressors with suction and discharge shut-off valve.

Condenser and gas cooler conditions:

$t_{GC} = 35^{\circ}\text{C}$, $p_h = 90 \text{ bar}$.

Compressor type	Motor version	Displacement at 50 Hz	Number of cylinders	Refrigerating capacity		Power consumption		Oil charge	Weight	Pipe connections		Motor	Electrical data	
				Q_o (kW) $t_o = -10^{\circ}\text{C}$	Q_o (kW) $t_o = +5^{\circ}\text{C}$	P_e (kW) $t_o = -10^{\circ}\text{C}$	P_e (kW) $t_o = +5^{\circ}\text{C}$			DL	SL		Max. operating current	Starting current (locked rotor)
		m ³ /h		kW	kW	kW	kW	dm ³	kg	mm	mm	V ①	A ②	A ③

ECOLINE compressors for transcritical CO₂ applications

2MTE-4K	2	3,3	2	6,56		3,85		1,2	94	18	22	Δ/Y (40S) 220..240V Δ-3-50Hz 380..420V Y-3-50Hz 440..480V Y-3-60Hz	14,2/8,2	76/44
2MTE-5K	1	3,3	2	6,56	11,35	3,85	4,02	1,2	95	18	22		19,8/11,5	108/62
2KTE-5K	2	4,8	2	9,54		5,60		1,2	96	18	22		19,8/11,5	108/62
2KTE-7K	1	4,8	2	9,54	16,50	5,60	5,85	1,2	96	18	22		27,9/16,1	143/82
4PTE-6K	2	4,3	4	7,82		4,95		2,0	115	18	22		18,7/10,8	108/62
4PTE-7K	1	4,3	4	7,82	13,80	4,89	5,02	2,0	118	18	22		26,5/15,3	143/82
4MTE-7K	2	6,6	4	12,91		7,57		2,0	118	18	22		27,7/16,0	143/82
4MTE-10K	1	6,6	4	12,79	22,50	7,81	7,81	2,0	120	18	22		37,9/21,9	168/97
4KTE-10K	2	9,6	4	19,17		11,07		2,0	120	18	22		38,8/22,4	168/97
4KTE-12K	1	9,6	4	19,29	34,00	11,03	11,33	2,0	121	18	22		47,1/27,2	181/105
4JTE-10K	2	9,3	4	19,60		11,01		2,6	179	18	28	PW (40P) ④ 380..420V Y/Y-3-50Hz 440..480V Y/Y-3-60Hz	21,1	59/99
4JTE-15K	1	9,3	4	19,59	33,60	11,05	11,25	2,6	182	18	28		30,2	81/132
4HTE-15K	2	12,0	4	25,06		13,83		2,6	182	18	28		27,1	81/132
4HTE-20K	1	12,0	4	24,70	42,60	13,84	14,04	2,6	187	18	28		39,2	97/158
4GTE-20K	2	15,0	4	31,30		17,66		2,6	187	18	28		35,7	97/158
4GTE-30K	1	15,0	4	32,10	54,70	17,43	18,02	2,6	211	18	28		51,4	135/222
4FTE-20K	2	17,5	4	36,60		20,60		2,6	187	18	28		42,0	97/158
4FTE-30K	1	17,5	4	37,70	63,10	20,30	21,00	2,6	211	18	28		58,7	135/222
4DTE-25K	2	22,0	4	47,00		26,80		2,6	211	18	28		51,9	135/222
4CTE-30K	2	26,0	4	55,80		31,40		2,6	211	18	28		62,6	135/222
6FTE-35K	2	26,0	6	56,00		31,30		2,8	233	28	35		65,0	165/275
6FTE-50K ⑥	1	26,0	6	56,00	92,20	31,30	31,70	2,8	243	28	35		95,9	226/404
6DTE-40K	2	30,3	6	65,10		36,30		2,8	238	28	35		75,9	219/362
6DTE-50K ⑥	1	30,3	6	65,10	107,00	36,30	36,70	2,8	242	28	35		98,0	226/404
6CTE-50K ⑥	2	38,2	6	81,70		46,30		2,8	241	28	35		99,0	226/404
8FTE-100K	2	69,4	8	161,00	260,00	83,00		5,5					Δ/Y (40D) 380..420V Δ-3-50Hz 440..480V Δ-3-60Hz	212,0
8FTE-140K	1	69,4	8	161,00	260,00	83,00		5,5	728	35	54	274,0		1159/342
8CTE-140K	2	99,2	8	230,00	372,00	124,30		5,5	726	35	54			

Tentative data

Technical data and performance data

Performance data 50 Hz

based on 10 K suction superheat and compressors with suction and discharge shut-off valve.

Condenser and gas cooler conditions:

$$t_{GC} = 35^{\circ}\text{C}, p_h = 90 \text{ bar.}$$

Compressor type	Motor version	Displacement at 50 Hz	Number of cylinders	Refrigerating capacity		Power consumption		Oil charge	Weight	Pipe connections		Motor	Electrical data	
				Q_o (kW) $t_o = -10^{\circ}\text{C}$ $t_o = +5^{\circ}\text{C}$	Q_e (kW) $t_o = -10^{\circ}\text{C}$ $t_o = +5^{\circ}\text{C}$	DL	SL			Max. operating current	Starting current (locked rotor)			
		m ³ /h		kW	kW	kW	kW	dm ³	kg	mm	mm	V ①	A ②	A ③

ECOLINE+ compressors for transcritical CO₂ applications

4PTEU-6LK	2	4,5	4	8,40		4,92		2,0	114	18	22	ΔY (40S) 220 .. 240V Δ-3-50Hz 380 .. 420V Y-3-50Hz 440 .. 480V Y-3-60Hz	15,8/9,1	88,5/51,0
4PTEU-7LK	1	4,5	4	8,40	14,67	4,87	4,99	2,0	114	18	22		22,3/12,9	117/67,0
4MTEU-7LK	2	6,9	4	13,69		7,44		2,0	111	18	22		23,7/13,7	117/67,0
4MTEU-10LK	1	6,9	4	13,68	23,50	7,42	7,54	2,0	113	18	22		36,0/20,8	140/81,0
4KTEU-10LK	2	9,9	4	19,71		10,33		2,0	112	18	22		35,9/20,7	140/81,0
4JTEU-10LK	2	9,7	4	21,00		10,68		2,6	179	18	22		31,7/18,3	158/91,2
4JTEU-15LK	1	9,7	4	20,90	34,60	10,73	10,97	2,6	182	18	22		46,4/26,8	206/119
4HTEU-15LK	2	12,4	4	27,00		13,38		2,6	182	18	22		40/23,1	206/119
4HTEU-20LK	1	12,4	4	25,80	43,40	13,09	13,32	2,6	187	18	22		64,3/37,1	301/174
4GTEU-20LK	2	15,5	4	32,60		16,77		2,6	187	18	22		57,3/33,1	301/174
4GTEU-30LK	1	15,5	4	32,80	55,80	16,56	17,14	2,6	211	18	22		79,7/46	385/222
4FTEU-20LK	2	18,1	4	38,10		19,59		2,6	187	18	22		66,3/38,3	301/174
4FTEU-30LK	1	18,1	4	38,60	64,40	19,30	20,00	2,6	211	18	22		93/53,7	385/222
4DTEU-25LK	2	22,7	4	48,50		24,70		2,6	211	18	22		84/48,5	301/174
4CTEU-30LK	2	26,9	4	57,60		29,40		2,6	211	18	22		100,8/58,2	385/222
6FTEU-35LK	2	26,9	6	60,00		30,80		2,8	235	28	35		101,5/58,6	407/235
6FTEU-50-LK	1	26,9	6	60,00	97,00	30,80	31,70	2,8	245	28	35		162,1/93,6	570/329
6DTEU-40LK	2	31,4	6	69,70		35,80		2,8	240	28	35		123,7/71,4	506/292
6DTEU-50LK	1	31,4	6	69,70	112,60	36,30	37,30	2,8	244	28	35		176,8/102,1	570/329
6CTEU-50LK	2	39,5	6	87,70		45,90		2,8	243	28	35		172,3/99,5	570/329

t_o Evaporating temperature (°C)
 p_h High pressure abs. (bar)
 t_{GC} Gas cooler outlet temperature(°C)

Oil heater

- // 230V
- 2MTE .. 4KTE: 0 .. 120 W
 - 4JTE .. 8CTE: 0 .. 140 W
 - 4PTEU .. 4KTEU: 0 .. 120 W
 - 6FTEU .. 6CTEU: 0 .. 140 W
 - self-regulating PTC heater

i Oil heater is generally required due to high solubility of CO₂ in the oil.

Explanations

- ① Tolerance (±10%) based on mean value of voltage range. Other voltages upon request.
- ② For the selection of contacts, cables and fuses the max. working current/max. power consumption must be considered. A fast overcurrent protection device is required.
Contactors: operational category AC3
- ③ Data for compressors with voltage 380 .. 420 V (220 .. 240 V) are based on an average voltage of 400 V (230 V).
Conversion factors:
380 V (220 V) 0.95
420 V (240 V) 1.05
- ④ PW: motor for part winding start winding partition 50%/50%
Select motor contactors for approx. 60% of the max. operation current.
- ⑤ Pipe connections may vary depending on the selected shut-off valve. See operating instructions KB-130.
- ⑥ Reduced voltage range:
- 380 .. 400/3/50
- 440 .. 460/3/60
- ⑦ Oil charge: BSE85K

Tentative data

Dimensional drawings

2MTE-4K..2KTE-7K

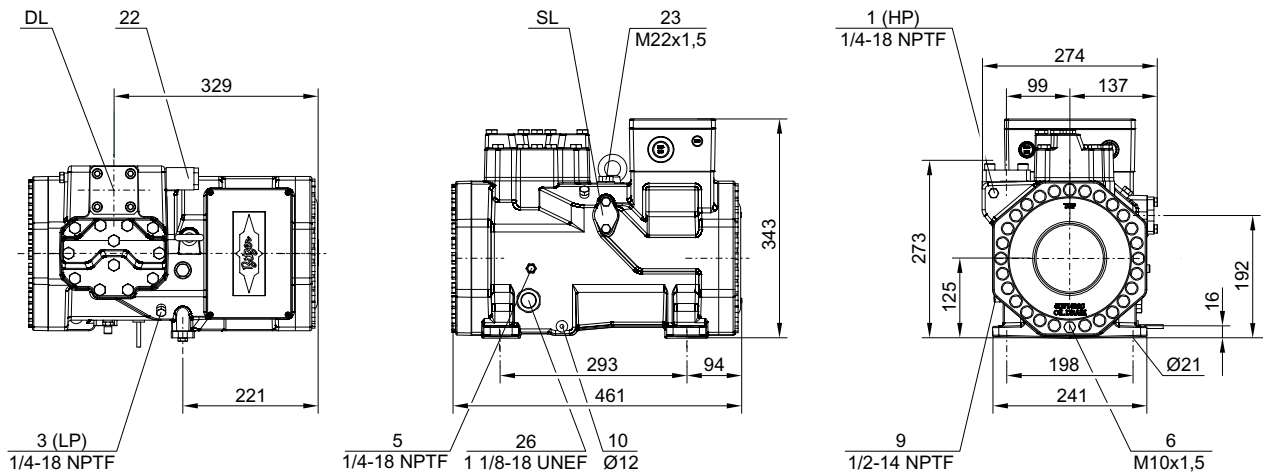

4PTE-6K..4KTE-10K, 4PTEU-6LK..4KTEU-10LK

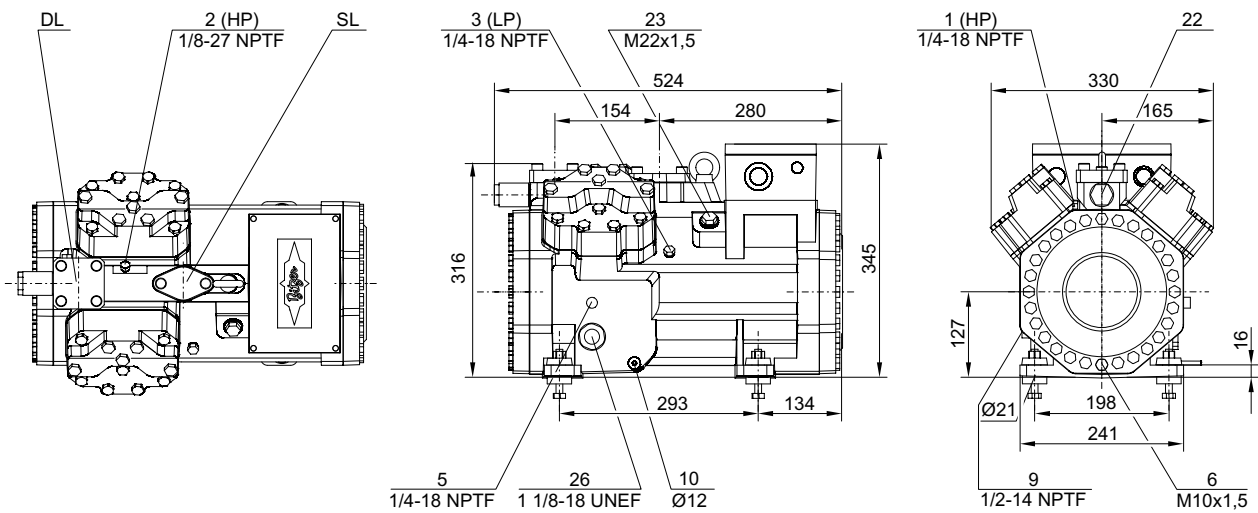

4JTE-10K..4FTE-20K, 4JTEU-10LK..4FTEU-20LK

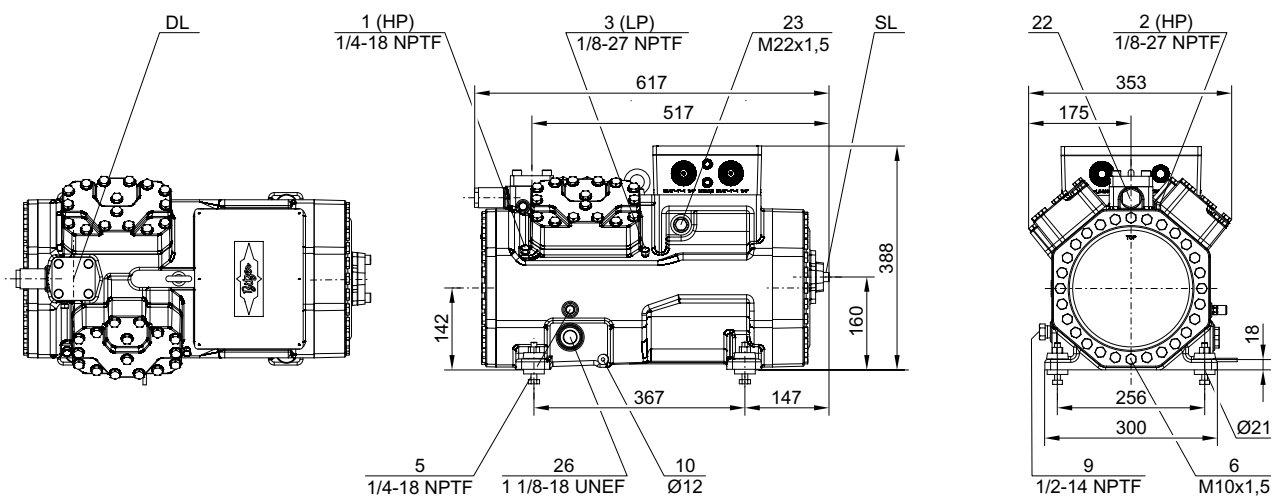

Connection positions see page 15

Dimensional drawings

4GTE-30K..4CTE-30K, 4GTEU-30LK..4CTEU-30LK

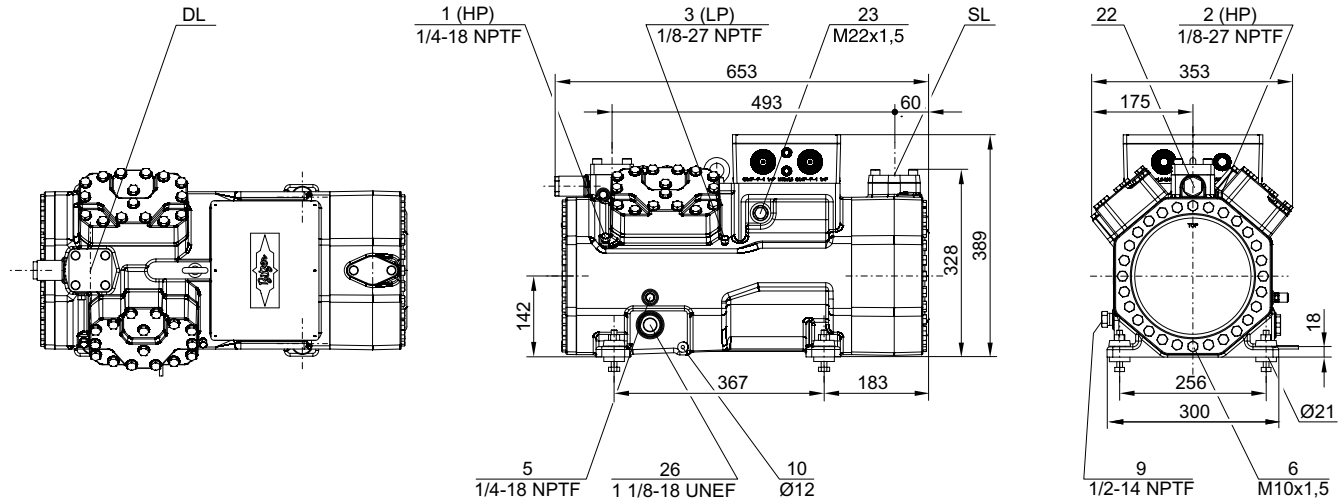

6FTE-35K..6CTE-50K, 6FTEU-35LK..6CTEU-50LK

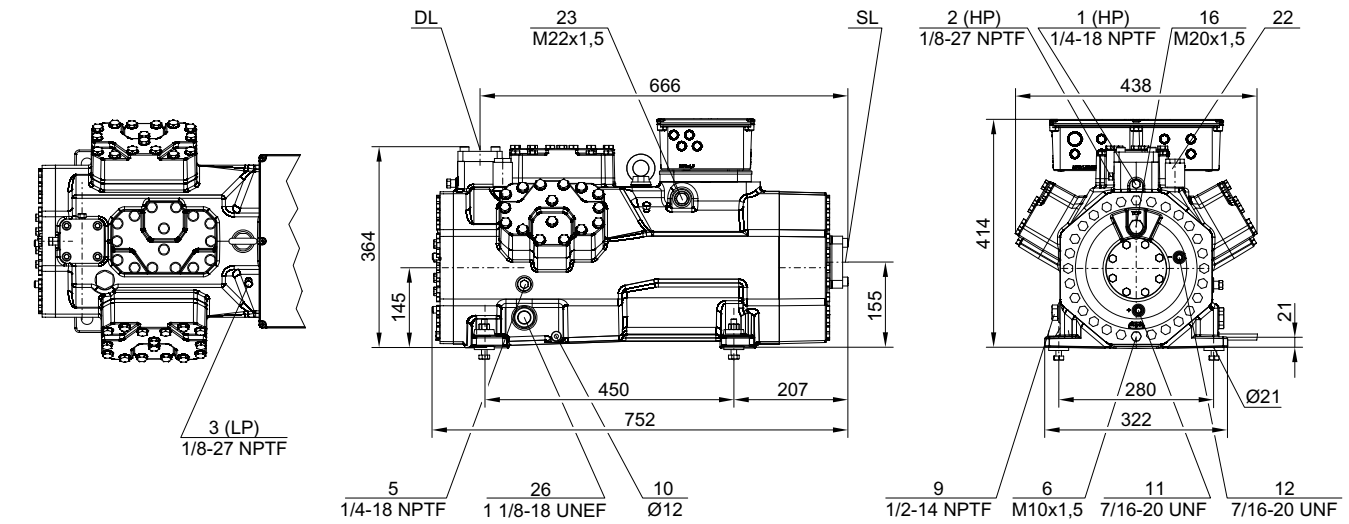

8FTE-100K..8CTE-140K

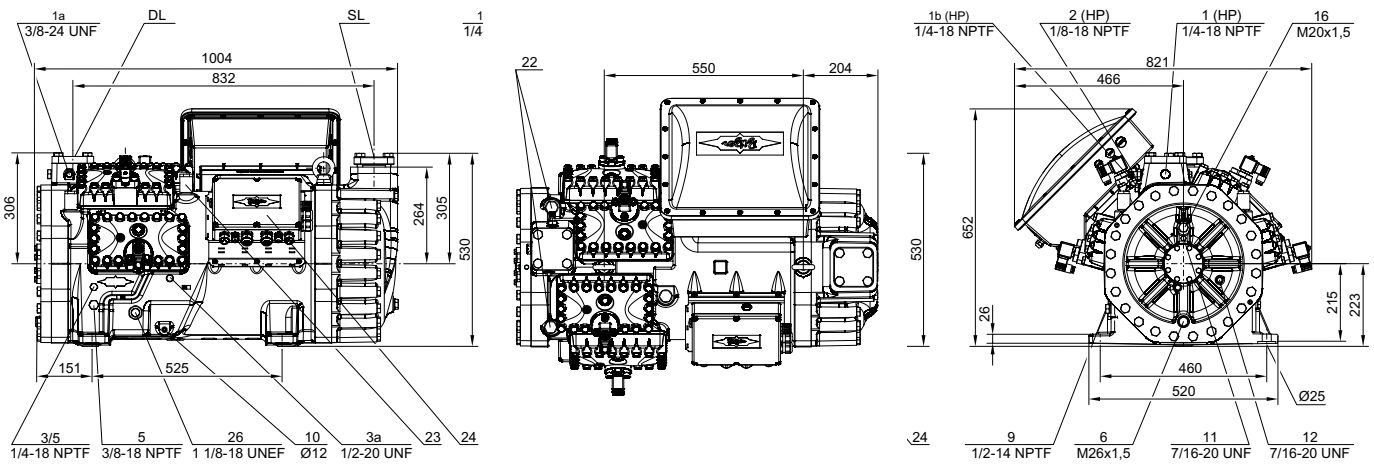

Connection positions see page 15

Connection positions

- 1 High pressure connection (HP)
 - 3 Low pressure connection (LP)
 - 5 Oil fill plug
 - 6 Oil drain
 - 9 Connection for oil and gas equalization (parallel operation)
 - 10 Crankcase heater
 - 11 Oil pressure connection +
 - 12 Oil pressure connection –
 - 16 Connection for oil monitoring
(opto-electronical oil monitoring "OLCK1" or differential oil pressure switch "Delta-PII")
 - 22 Pressure relief valve to the atmosphere (HP)
 - 23 Connection for pressure relief valve (LP) to the atmosphere
 - 26 Sight glass
-
- SL Suction shut-off valve
 - DL Discharge shut-off valve

See Technical Information KT-230 and KT-231 for dimensional drawings with accessories.



BITZER Kühlmaschinenbau GmbH
Peter-Schaufler-Platz 1 // 71065 Sindelfingen // Germany
Tel +49 7031 932-0 // Fax +49 7031 932-147
bitzer@bitzer.de // www.bitzer.de

Subject to change // 80104602 // 09.2022